

IMPORTANT: Unless certified or exempted by The California ARB, Headers are not legal for sale in California on 1975 or later model vehicles, except for racing vehicles which are not legal for use or operation on any highway. Pre-Catalyst vehicles must utilize original air injection system if so equipped. It is the responsibility of the customer to reinstall the air injection device to his vehicle.

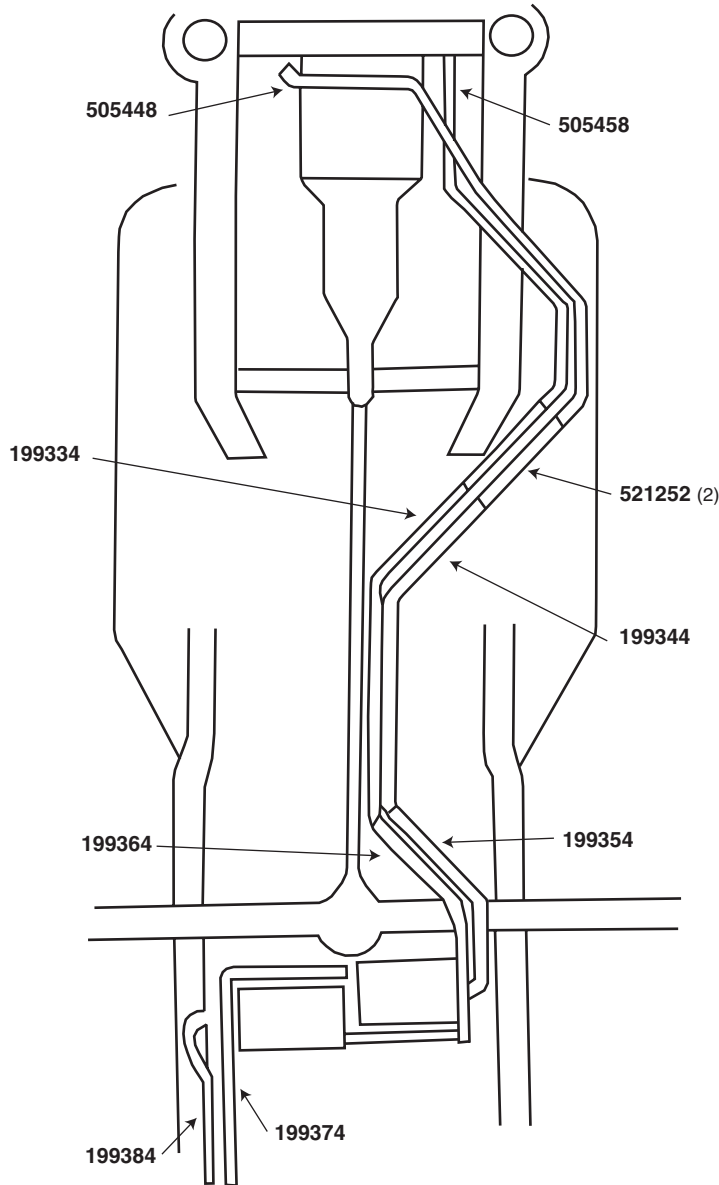

2701 N. Dettman Rd.  
Jackson, MI 49201

**INSTALLATION INSTRUCTIONS**  
**NUMBER: 89009**

1982 Chevrolet Camaro & Z28  
Firebird/Trans Am w/Chevrolet Engine  
305-400 CID Eng.

**NOTE: HEADER DUALS.** THIS KIT WAS DESIGNED FOR DYNOMAX HEADER #85012. IF THE KIT IS BEING INSTALLED WITH HEADERS OTHER THAN LISTED ABOVE, MODIFICATION WILL BE REQUIRED. DYNOMAX WILL NOT ASSUME RESPONSIBILITY FOR FIT OR PERFORMANCE.

**NOTE: MUFFLERS AND MUFFLER U-CLAMPS ARE NOT SUPPLIED WITH THIS PERFORMANCE EXHAUST SYSTEM.** DYNOMAX HAS DESIGNED THIS KIT FOR USE WITH SUPER TURBO MUFFLER PART #17731, OR AN EQUIVALENT 2¼" I.D. INLET x 2¼" I.D. OUTLET, SINGLE OFF SET OEM MUFFLER. GLASSPACK MUFFLERS MAY BE USED WITH SLIGHT MODIFICATIONS.

**DANGER WARNING:** SHOULD THE PURCHASER DECIDE TO INSTALL ANY EXHAUST PRODUCT AT HOME, BE WARNED THAT PASSENGER CAR OR LIGHT DUTY TRUCK/VAN "BUMPER" JACKS ARE INTENDED FOR EMERGENCY USE ONLY. THE USE OF FRAME CONTACT JACK STANDS IN CONJUNCTION WITH A FLOOR JACK AS MAIN SUPPORT IS HIGHLY RECOMMENDED TO MINIMIZE ACCIDENTAL DROPPING OF A VEHICLE DURING THE INSTALLATION PROCESS.

1. Bolt left side Header ext. **#505448** to left side Header. Check clearance between oil pan, cross member and frame. Cut plastic splash shield to clear head pipe. **Do not tighten.**
2. Bolt right side header ext. **#505458** to right side Header. It goes behind and inside of left ext. **Do not tighten.**
3. Install **#521252** left and right and clamp with double 2¼" U-Clamps. Tighten extensions at Header and check for clearance.
4. Install **#199344** & **#199334**. Use 2¼" double U-Clamps and with **#199344** level through the drive shaft tunnel, tighten clamp enough to hold in place. **#199334** runs outside and above **#199344** approximately ½". Tighten clamp enough to hold in place.
5. Drill a hole in the sub-frame above the second 2¼" double U-Clamp. Using sheet metal screw, fender washer and hanger; bolt to frame and clamp to header extension.
6. Install **#199354** & **#199364** over rear axle. Slip **#199354** onto **#199344**. Slip **#199364** onto **#199354**. **#199364** goes on top of **#199354** at muffler. **Do not tighten.**
7. Install left muffler with center connection onto **#199354** and offset connection towards front of car (See drawing). Bracket **#199354** LG Frame using **#107097**, **#520862**, 5/16" bolt, nuts and lock washer. Remove stock bracket from frame and use rear hole and stock bolt for **#107097** bracket
8. Install right hand muffler per drawing to **#199364** leaving approximately 3/8" gap between the muffler case.
9. Install **#199384** & **#199374**. **#199384** goes above **#199374**.
10. Bracket tail pipe **#199374** & **#199384** above **#199374** using double 2¼" U-Clamps, **#107097** bracket and **#520862** hanger.
11. Align and tighten all clamps, brackets and bolts.
12. Periodically check tightness of all Header Bolts.

### Parts List

1	505448	1	199354
1	505458	1	199364
2	521252	1	199374
1	199344	1	199384
1	199334		

### PARTS KIT

3	Double 2¼" Clamps (2 Clamps welded together)	9	5/16" Nuts
4	2¼" Clamps	9	5/16" x 1½" Cap Screws
3	107097 Brackets	3	Sheet Metal Screws
3	520862 Hangers	6	3/8"-16 x 1" Screws
9	Fender washers	6	3/8" Lock washers
9	5/16" Lock washers	6	3/8" Nuts