



## Summit Racing RPM activated switch

Thank you for purchasing the Summit RPM Activated Switch. The addition of this kit will allow you to control an external device when the customer selected RPM is reached. **\*\* NOTE: before beginning the installation of this kit please disconnect the positive battery cable from your vehicle and read all the instructions completely! \*\***

### Mounting

- Red wire attaches to a switched +12 Volt supply source.
- Black wire attaches to chassis ground.
- Grey wire is input for the Tachometer signal.
- Blue wire is either Normally Open (Blue wire provides ground **AFTER** the switch reaches desired RPM) or Normally Closed ( Blue wire is ground **UNTIL** switch reaches desired RPM.) according to the position of Invert "INV" switch (OFF means Normally Open and will supply ground when the selected RPM is reached, ON means Normally Closed and the switch will open when the selected RPM is reached).

**\*\*Note: If the device to which the blue wire is attached to draws more than 3 amps, a relay must be used to drive that device or damage will occur to the unit.\*\***

### Operation

- For this unit to function correctly, the dip switches must be set to the desired RPM. Two sets of switches are in this unit. One set is for the thousands RPM digit from 2000 to 9000. The other is the hundreds RPM digit from +100 to +900 (there is no switch for 000 hundreds). Though not recommended, If more than one switch is ON for each digit the unit is designed to assume the smallest RPM value. To turn a switch "ON", simply push the switch to the **OUTSIDE**, away from the center of the circuit board.
- The unit can be used with different cylinder engines. The CYL1 and CYL2 switches can be used to set the Cylinder type.

CYL2	CYL1	
OFF	OFF	4 Cylinders
OFF	ON	6 Cylinders
ON	OFF	8 Cylinders
ON	ON	10 Cylinders

**\*\* Note: The default CYL1 = OFF and CYL2 = OFF is for 4 Cylinder.**

- For example, if you wish to activate a device at 3000 for an 8 CYL engine, set the thousands switch up to the ON position and set CYL2 = ON and CYL1 = OFF
- The device will be activated after reaching 3000 RPM.
- The Green LED inside the unit turns on when power is supplied to the unit.
- If the INV switch "Normally Open" is selected, the blue LED light and your device will turn on after reaching the selected RPM
- If the INV switch "Normally closed" is selected the blue LED light and your device turns on immediately and will turn off when the selected RPM is reached.

CYLINDER SELECTION SWITCHES

CYL1	CYL2	
OFF	OFF	4CYL
OFF	ON	6CYL
ON	OFF	8CYL
ON	ON	10CYL

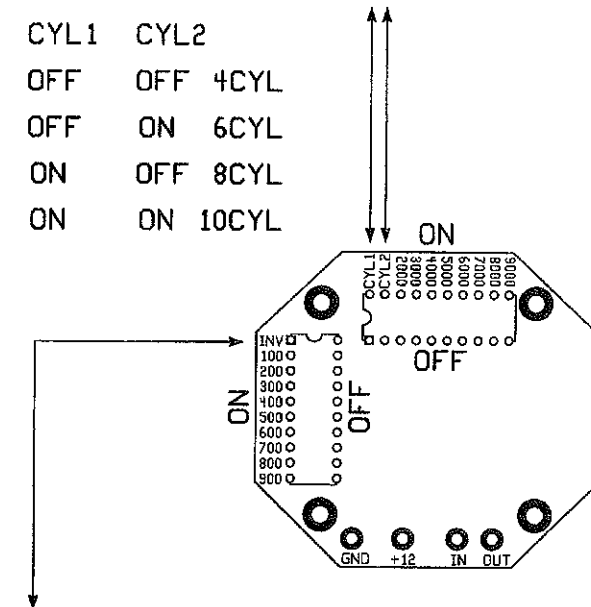

INV (invert) SWITCH

ON NORMALLY CLOSED

OFF NORMALLY OPEN

SUMMIT RACING  
RPM ACTIVATED SWITCH

Co:	SUMMIT RACING
Title:	RPM ACTIVATED SWITCH
Board:	DIP SWITCHES