



Hella FF Series Lamp System Installation Instructions & Owner's Guide

Congratulations! You are now the proud owner of one of the world's most powerful lamps and advanced lighting products available today!

The **Hella FF Series Lamp System** features a revolutionary innovation in reflector design that creates an extremely powerful and accurate beam of light. The computer designed reflector uses over 50,000 precisely calculated surface points to aim the beam exactly where it is needed. This allows the Hella FF Series to put up to 60% more light on the roadway than conventional lamps and creates a wider, more effective beam pattern.

It is the same technology that endurance racers use to win races all over the world. The confidence you have placed in our products and in our company is very important to us. We appreciate your choice of a Hella product, and your complete satisfaction with our products over

many miles and years is our continual goal. Should you have any questions or comments about your Hella product, please contact us by mail, toll-free phone, fax, or E-mail listed below.

Thank you for choosing Hella!

Mitch L. Williams
President and CEO

**Hella, Inc., 201 Kelly Drive
Peachtree City, GA 30269, USA
(800) 247-5924
Fax (800) 631-7575
E-mail Hella.FAQ@HellaUSA.COM**

Kit Contents

Before assembly, please check and familiarize yourself with the contents of your *Hella FF Series* Lamp System.

- Contents:
- (2) **Hella FF Series** Lamps
 - (1) Wiring harness

- (2) Mounting bolts, nuts, & washers
- (1) "Scotch-lock" connector
- (1) Illuminated push switch
- (6) Tie wraps
- (1) Pry tool

Tools Required

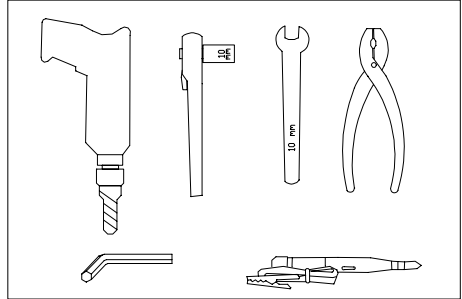

- Electric drill
- 1/4" (6.5mm), and 1/2" (13mm) drill bits
- 10mm wrench
- Ratchet with 10mm socket
- Pliers
- Circuit tester
- 3/16" (5mm) hex head wrench

Preparation

1. Please read and follow all instructions carefully to make sure you have a proper and legal installation.
2. Consult your local and state regulations regarding minimum and maximum mounting height above the ground, or specific requirements.
3. Determine the best mounting position for your vehicle. The **Hella FF Series** lamps are designed to be mounted above or below the bumper.
4. Mount both of the lamps at the same height. Position the lamps at an equal distance from the center of the vehicle and as far apart as possible. **(See Fig. 1)**

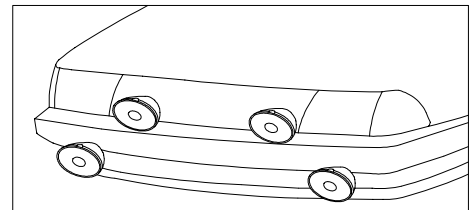

Fig. 1

CAUTION: Make sure the auxiliary lamps do not restrict airflow to the radiator or obstruct the headlamps, turn signals, or marker lamps.

Mounting

1. The **Hella FF Series** Lamps come with the bracket already attached. **See Fig. 2** if it is necessary to rotate or flip the bracket to better suit your mounting.

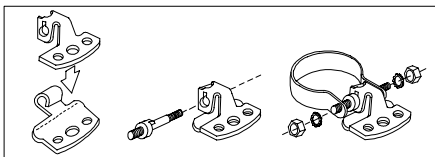

Fig. 2

2. Mark the mounting points on the bumper and drill 1/4" diameter holes for pendant

or upright mounting.

3. Attach lamp base to the bumper. Do not tighten completely until lamp is properly aimed. **(See Fig. 3)**

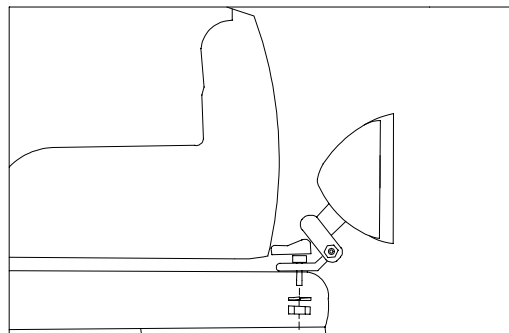

Fig. 3

4. Depending on your mounting (pendant or upright), it may be necessary to flip the lens on the lamps. The **Hella** logo should always be right side up for a proper beam distribution. To detach the lens, pry under the top or bottom locking tab. **(See Fig. 8)** Rotate the lens and reinstall in the housing. **CAUTION:** Make sure none of the bulb wires are being pulled or pinched between the housing and the lens.

Wiring Harness Installation

1. Locate the low beam or high beam lead on one headlamp by using a circuit tester. Use the following procedure:

- a. **For Fog Lamps:**
Turn on the low beam headlamps. Connect the end of the circuit tester to ground (-) and use the tester to locate the headlamp low beam lead. Turn off the ignition and the headlamps. Disconnect the battery.
- b. **For Driving Lamps:**
Turn on the high beam headlamps. Connect the end of the circuit tester to ground (-) and use the tester to locate the headlamp high beam lead. Turn off the ignition and the headlamps. Disconnect the battery.

2. Refer to Fig. 4 and Fig.5 for diagram of wiring procedure.
Note: The Hella Wiring Harness supplied with this kit is a complete assembly. It is fully insulated and sleeved. All connections are pre-terminated.

3. Mount Relay as follows: (See A in Fig. 4)

- a. Position the relay upright on the battery side of the engine compartment in an area that is not exposed to water spray, excessive heat, or moving parts.
- b. Make sure the relay is mounted close enough to the battery so the power lead will easily reach the positive (+) terminal of the battery.

4. Connect the relay power lead to the battery as follows: (See B in Fig. 4)

- a. Route and attach the power lead (with in-line fuse) to the positive (+) battery terminal.
- b. Connect the ground wire to a vehicle chassis ground or the negative (-) battery terminal. (See C in Fig. 4)

5. Route wires to the switch as follows: (See D in Fig. 4)

- a. Find an unused grommet in the engine firewall. If an unused grommet cannot be found,

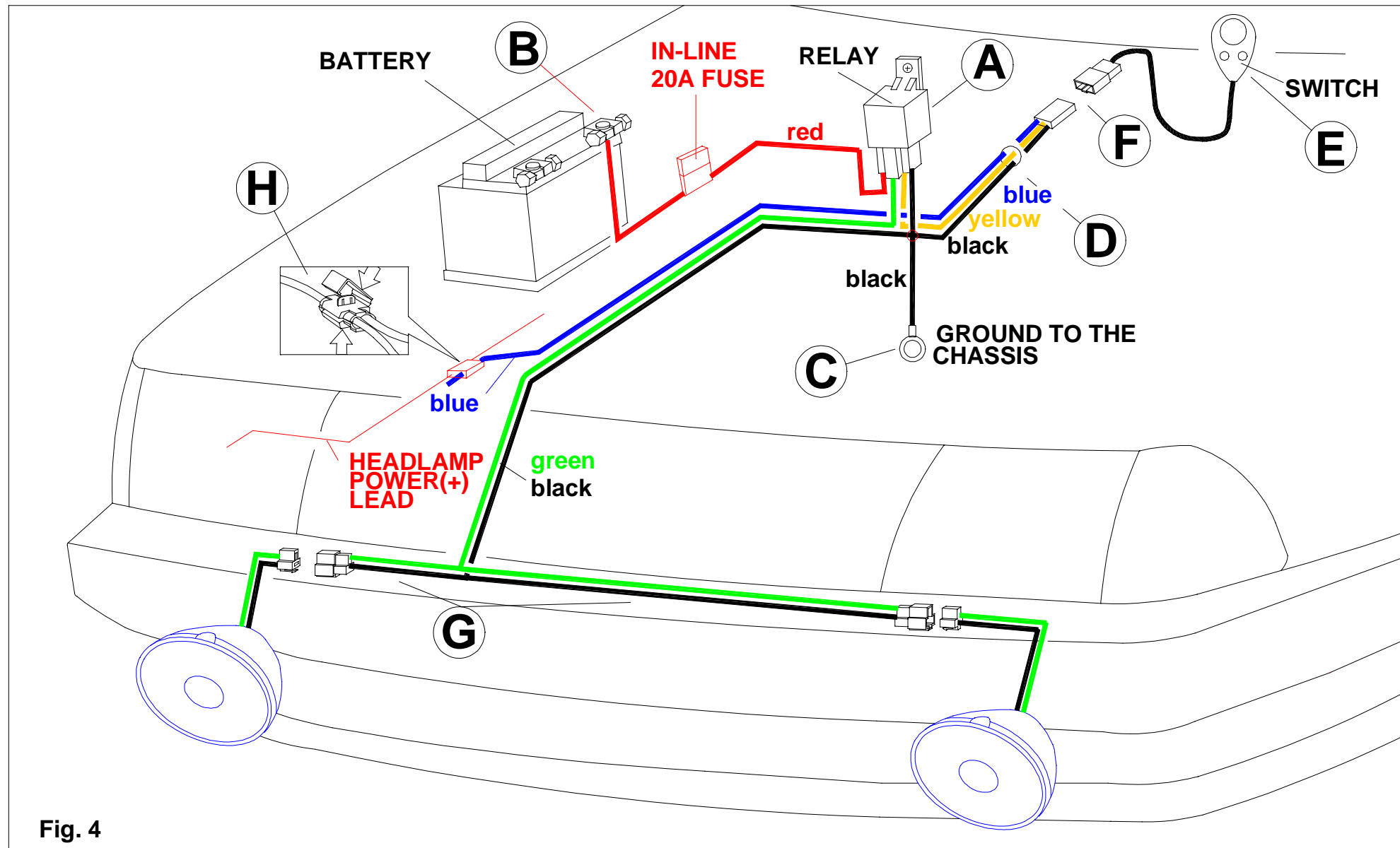

Fig. 4

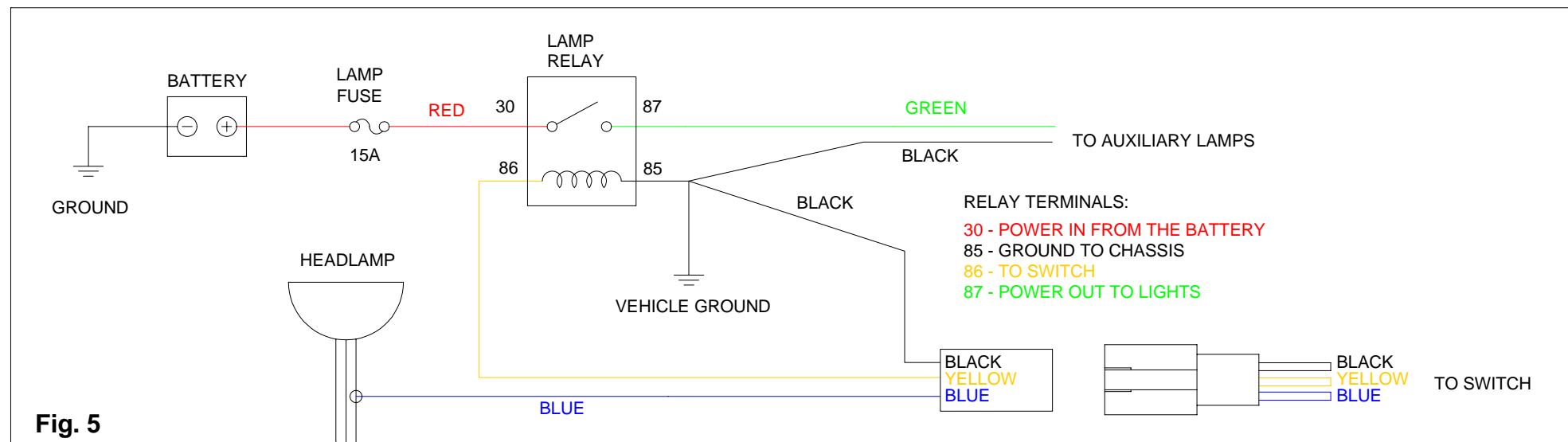

Fig. 5

- a. drill a 1/2" hole in an area with clear access to both sides away from any moving parts or other wiring.
- b. Route the switch connector through the firewall into the vehicle interior near the location of the switch.

6. Install switch as follows: (See E in Fig. 4)

- a. Select a location for the switch (i.e. dashboard or center console). Make sure there is sufficient space to install the switch. Look for areas to route the switch wires so they will be out of the way (gaps between trim panels for example).
- b. Clean and dry the surface where the switch is to be mounted. Remove the tape backing from the switch and mount the switch.
- c. Plug the connector from the wiring harness into the switch connector. (See F in Fig. 4)
Caution: Be sure to secure all loose wires to keep them from interfering with the safe operation of the vehicle.

7. Route harness to auxiliary lamps as follows: (See G in Fig. 4)

- a. Route the two sets of auxiliary lamp leads with connectors to the lamps.
Note: Route the shorter lead to the lamp on the battery side and the longer lead to the lamp on the opposite side.

8. Connect the auxiliary lamp relay power (+) lead (blue) as follows: (See H in Fig. 4)

- a. Route the single blue wire to the low beam power (+) for **Fog Lamps**, or to the high beam power (+) for **Driving Lamps**.
- b. Attach blue wire to the high or low beam lead as indicated in 8a with the "Scotch-lock" connector.

9. Test the operation of the lamps as follows:

- a. Re-connect the battery.
- b. Turn on ignition switch and low beam headlamps for **Fog Lamps**, or high beam headlamps for **Driving Lamps**.
- c. Activate auxiliary lamp switch. **If lamps do not illuminate, check fuse and all wiring connections.**

10. Use wire ties to secure any slack portion of the harness in the engine compartment away from moving parts or excessive heat.

Lamp Aiming

1. Loosen the bolt on the lamp bracket. Adjust the position of the lamps by pivoting the lamp housing in a vertical or horizontal direction.
2. Position the vehicle on a flat surface at a distance of 25' (7.6 m) from a wall. (See Fig. 6)
3. Measure the distance from the center of the lamp to the ground and mark off the same height on the wall.
4. For **Fog Lamps**, adjust them so the top of the beam is 4" (102mm) below the center line mark on the wall.
5. For **Driving Lamps**, adjust them so the bright spot of the beam pattern is on the centerline mark on the wall.

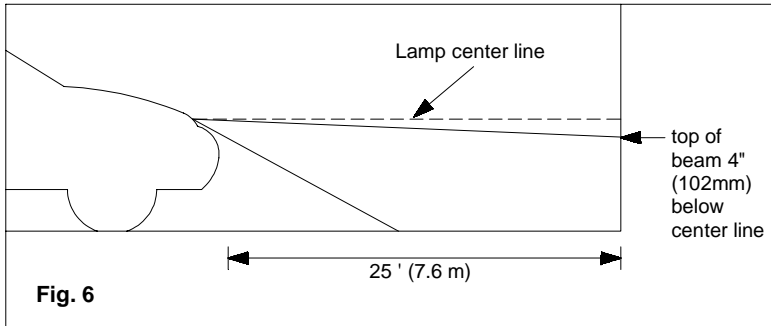

If you have any questions or comments, please consult your local automotive technician or call:

Hella Customer Service
Hella, Inc., 201 Kelly Drive
Peachtree City, GA 30269, USA
(800) 247-5924
E-mail
Hella.FAQ@HellaUSA.com

Bulb Replacement

Note: Only Use 55W H3 Bulbs
(See Fig. 7)

IMPORTANT: Do not touch the Halogen bulbs with bare hands, as this will reduce bulb life. If bulbs are touched accidentally, clean them with a tissue and rubbing alcohol.

1. Use the included pry tool to remove the lens by prying under the top or bottom locking tabs. (See Fig. 8)
2. Remove the wire leads from the bulb holder and the bulb power lead.
3. Replace bulb and reconnect the black wire lead to the bulb holder and the white wire lead to the white bulb power lead.
4. Reinstall the lens into the lamp housing.
NOTE: Make sure that the **Hella** logo is right side up.
CAUTION: Make sure none of the wires are being pulled or pinched between the housing and lens.

